

Automatic Railway Crossing System

Lekha M.S¹, S.Sai prashanth², V.Srimaan³, Venkat Rohit⁴

¹ Assitant professor, SRM institute of science and Technology, Chennai, Tamil Nadu, India.

^{2, 3, 4} SRM institute of science and Technology, Chennai, Tamil Nadu, India.

Abstract – The objective of this paper is to provide an automatic railway gate at a level crossing replacing the gates operated by the gatekeeper. The system reduces the time for which the gate remains closed. This type of gates can be employed in an unmanned level crossing where the chances of accidents are higher and reliable operation is required. Since, the operation is automatic, error due to manual operation is prevented. The system works on a microcontroller based control. The proposed 16A microcontroller. With the help of IR sensors .The arrival and leaving of the system is monitored and the gate is operated accordingly.

Index Terms – ATmega16A, I R Transceiver, Microcontroller, Automatic railway gate control system.

1. INTRODUCTION

This paper deals with a topic of much contemporary relevance. It proposes a unique and economical method for improving the safety of our level crossings. Road accidents at railway gate is a leading cause of death and injury worldwide. Surveys conducted by Indian Railway found that about 17% of total railway accidents in India is crossing accidents of which majority occurs at passive railway crossings. The operation of railway gates at level crossings is not so reliable nowadays. Primarily the road users have to wait a very long time before the arrival of train and even after the train is left. And secondly the chances of accidents that usually made by the carelessness of the road users or due to the time errors made by the gatekeepers is more. Here comes the importance of automatic railway gate control system.

In this project we detect the arrival of train and warn the road users about the arrival of train .If no obstacle is found a green signal is given for the train to pass, otherwise a red signal is given to slow down. After the obstacles are cleared, the gate is closed and train is passed .We will make sure that the train is passed and reopen the gate. The system deals with two things. Firstly, it deals with the reduction of time for which the gate is being kept closed. And secondly, to provide safety to the road users by reducing the accidents. In the automatic railway gate control system, at the level crossing the arrival of the train is detected by the sensor placed near to the gate. Hence, the time for which it is closed is less compared to the manually operated gates and also reduces the human labour.

2. INTERFACING OF SERVO MOTOR

A servo is a mechanical motorized device that can be instructed to move the output shaft attached to a servo wheel

or arm to a specific position .Inside the servo box is a dc motor mechanically linked to a position feedback potentiometer, gearbox, electronic feedback control loop circuitry and a motor drive electronic circuit

Servos are controlled by sending them a pulse of variable width. The control wire is used to send this pulse. The parameters for this pulse are that it has a minimum pulse, a maximum pulse, and a repetition rate. Given the rotation constraints of the servo, neutral is defined to be the position where the servo has exactly the same amount of potential rotation in the clockwise direction as it does in the counter clockwise direction. It is important to note that different servos will have different constraints on their rotation but they all have a neutral position, and that position is always around 1.5 milliseconds (ms).

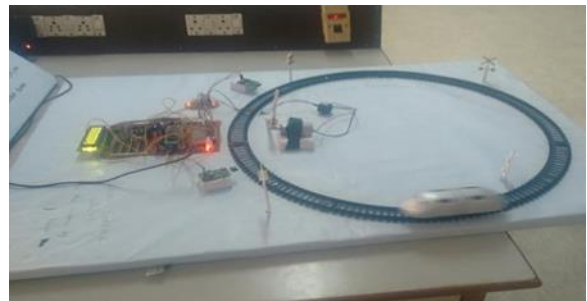

The angle is determined by the duration of a pulse that is applied to the control wire. This is called Pulse width Modulation The fig 2.2 shows the interfacing of servo with microcontroller. The servo expects to see a pulse every 20 ms. The length of the pulse will determine how far the motor turns. For example, a 1.5 ms pulse will make the motor turn to the 90 degree position (neutral position).When these servos are commanded to move they will move to the position and hold that position. If an external force pushes against the servo while the servo is holding a position, the servo will resist from moving out of that position. The maximum amount of force the servo can exert is the torque rating of the servo. Servos will not hold their position forever though; the position pulse must be repeated to instruct the servo to stay in position.

When a pulse is sent to a servo that is less than 1.5 ms the servo rotates to a position and holds its output shaft some number of degrees counter clockwise from the neutral point. When the pulse is wider than 1.5 ms the opposite occurs. The minimal width and the maximum width of pulse that will command the

servo to turn to a valid position are functions of each servo. Different brands, and even different servos of the same brand, will have different maximum of each servo. Different brands, and even different servos of the same brand, will have different maximum and minimums. Generally the minimum pulse will be about 1 ms wide and the maximum pulse will be 2 ms wide.

Another parameter that varies from servo to servo is the turn rate. This is the time it takes from the servo to change from one position to another. The worst case turning time is when the servo is holding at the minimum rotation and it is commanded to go to maximum rotation. This can take several seconds on very high torque servos.

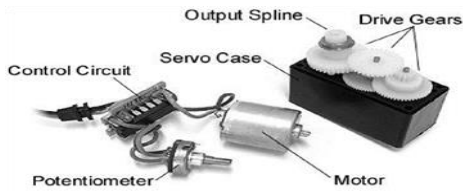

3. IR TRANSCEIVER

IR transceiver is used here for determining the arrival and departure of train. This is done by using IR Transceiver in which presence of train is detected as logical zero.

A. Transmitter

The Infrared Emitting Diode (IR333/H0/L10) is a high intensity diode, molded in a blue transparent package. The device is spectrally matched with phototransistor, photodiode and IR receiver module. It finds applications in IR remote control units, smoke detectors, free air transmission systems etc.

B. Receiver

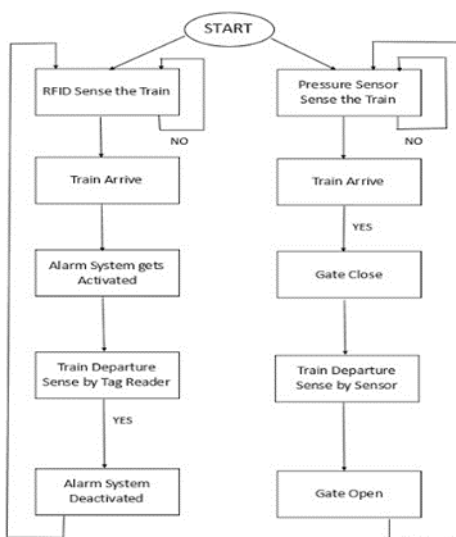
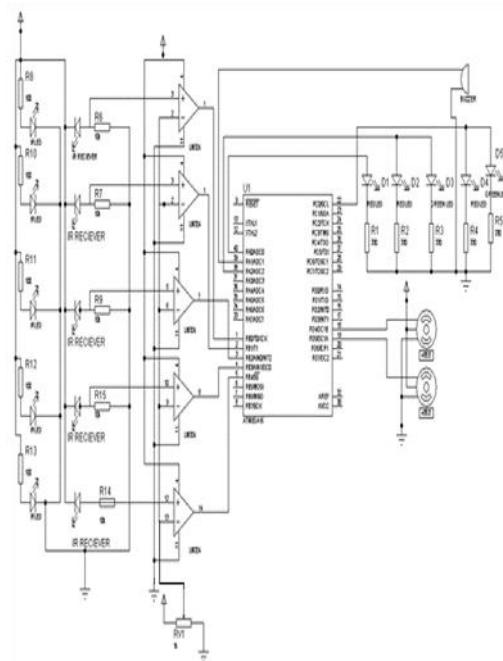

Fig:3.1

The IR LED converts the incident IR radiations to an equivalent electric current which when passed through a resistor results in a certain amount of voltage drop. This value of voltage will depend upon the intensity of incident IR radiations or in other words, the distance between IR transmitter and receiver. The receiver is connected in reverse bias in the circuit. The IR rays emitted by the transmitter get reflected back after hitting the target. Receiver converts this received radiations to a corresponding electric current.

4. CIRCUIT DIAGRAMS AND OPERATION

One of the major advantages of this system is its simple circuit and working principle. The circuit is divided into three parts. First one is the microcontroller section second is the IR sensor section kept on rail and third is the servo motor which is used to operate the gate. All of them are discussed in detail in coming sections. The fig 4.1 shows the detailed circuit diagram of the system. By employing the automatic railway gate control at the level crossing the arrival of train is detected by the sensor placed on either side of the gate at about 5km from the level crossing. Once the arrival is sensed, the sensed signal is sent to the microcontroller and it checks for possible presence of vehicle between the gates, again using sensors. Subsequently, buzzer indication and light signals on either side are provided to the road users indicating the closure of gates. Once, no vehicle is sensed in between the gate the motor is activated and the gates are closed. But, for the worst case if any obstacle is sensed it is indicated to the train driver by signals (RED) placed at about 2km and 180m, so as to bring it to halt well before the level crossing.



5. RESULT

Following results have been obtained from the implementation of the proposed system:

- 1) Wide Control Range-The pressure sensor senses the train and at the same time RFID also senses the train, which gives the information about the train like speed, location etc.
- 2) High Reliability- The proposed system is highly stable as the pressure sensor and RFID tag remain unaffected from the climate and also perform fast operations.
- 3) Easy Implementation-The system is easily implementable, follows simple procedures to perform operations at low operating costs.
- 4) Independent Components- In case of any failure of any of the three components, rest two will work making the system go on as such.



6. CONCLUSION

This paper concludes that the alarm system based on Servo motor, Pressure sensor and RFID improves the reliability of automatic railway gate control system. It also gives the speed and location of the train.

7. FUTURE SCOPE

Since this proposed model suffers from the drawback that it cannot be used for very high speed trains and at the hilly areas where the pressure sensor may not perform correctly, hence future work can concentrate on making it possible work on high speeds too.

REFERENCES

- [1] H.Ngwe, Y.Pwint, "Automatic Railway Gate Control System Using Microcontroller," *IJSETR Volume 3, Issue 5, May 2014*.
- [2] F.Maier and A.Bigdeli, "Obstacle-free determination for rail track maintenance vehicles," 11th International Conference on Control Automation Robotics & Vision (ICARCV).IEEE, pp.2172-2178, 2010.
- [3] Y.Lei, H.Xiao, "Research on alarm system of railway crossing based on GPS and GPRS," IEEE China 2011".
- [4] H.Salmane, "A video – Analysis Based Railway-Road Safety System for Detection Hazard Situation at Level Crossings," IEEE Transactions on Intelligent Transportation Systems, vol.16, no.2, April 2015.
- [5] J.Xuer, "Visual Monitoring Based Railway Grade Crossing Surveillance System," Congress on Image and Signal Processing, 2008.